

PHASED DELTA LOOPS

"Inverted Deltas"

IZ5 L J B

www.iz5ljb.eu

Average elements distance = 14m = 63,5°

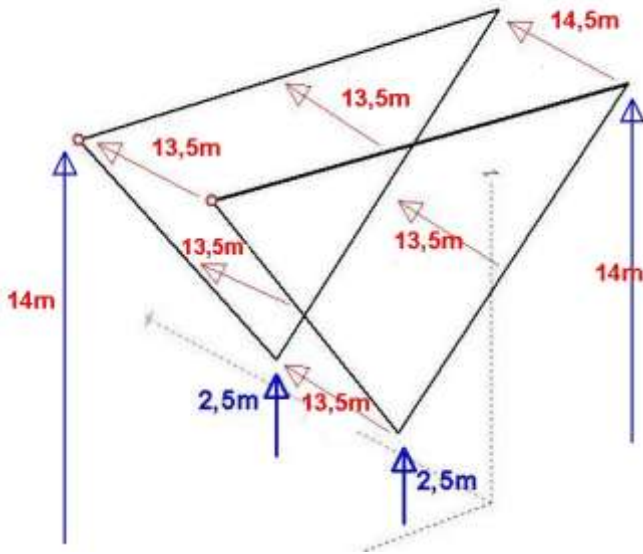

Currently my 'provisional' 80m antenna experiment consists of TWO Phased 'Inverted' DELTA LOOPS, VERTICAL polarisation. Average Elements distance is about 63 degree. The average Antenna height is 13-14 m.

Following the wise suggestions of Bob 11BAW I used VERTICAL POLARISATION feeding at the upper corners of the triangle's bases (inverted deltas) to elevate the antenna field from the ground. For this it is necessary to connect, at the feed point, the hot of the coax with the vertical wire running to the ground direction and the shield to the inverted triangle's top base parallel to the ground.

The feed point's impedance is 50 Ohm @ 3.770 MHz for both antennas mounted singularly (only one loop in the air). When mounting both antennas the SWR goes to 1:1 @ 3.8 MHz, just a little bit upper, due to the element's coupling.

To phase the two loops, Dr. Ace WH2T suggested me to simply use quarter-wavelengths of 75-ohm coaxial cables feeds placed from any of the delta's feed-points simply to a PL259 T-splitter going to the RTX with a standard RG213 50 Ohm coax. Initially I used this system for BROADSIDE phasing and the phased Deltas were running well with a swr 1:1 @ 3.780 MHz.

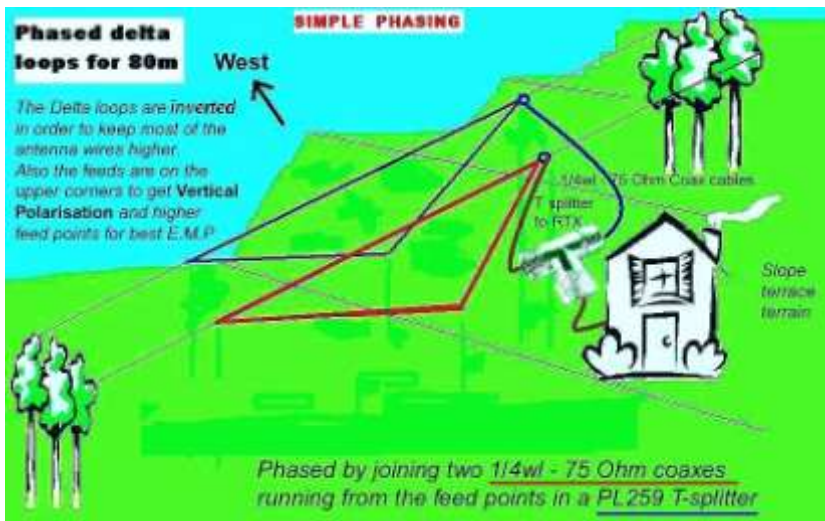

This system of BROADSIDE phasing is very simple and uses just two 1/4 wl 75 Ohm coaxes joined together (it is not actually a 'real' broadside because the loop antennas are clearly able to beam in 2 directions only that are perpendicular to the loop plane).

This simple phasing method is possible because of the special characteristic of the quarter-wave lambda coax transformer : "the current at the load end of a 1/4 lambda line equals the applied voltage divided the impedance on the line REGARDLESS of the load; additionally the PHASE shift will be 90 degrees REGARDLESS of the load impedance; this law is true also for odd multiples of 1/4 lambda".

The signals in this way are at least about 3 to 5 dB more than with a single element.

Nevertheless Paul N2PL, to 'simulate' an ENDFIRE phasing, uses the two 75 Ohm 1/4 wave matching sections and a relay to place a 50 Ohm Delay Phasing Section in series to the opposite direction of the chosen bearing of the 2 elements beam, in this way it is possible to have West and East beaming and the phasing section is calculated in order to get the best F/B and max gain →

I decided to unite these 2 systems of N2PL and WH2T using relays to choose from BROADSIDE or ENDFIRE (E or W).

I also thought to use relays to switch not only the hots but also the grounds of the antenna's coaxes.

11BAW suggested me this method: he wrote very interesting articles on the effects of the ground system on our stations....

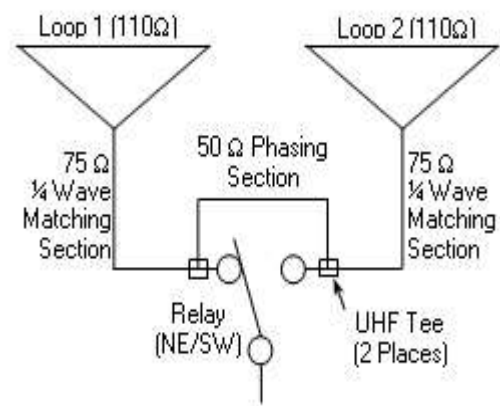

THIS IS MY DESIGN OF THE SYSTEM :

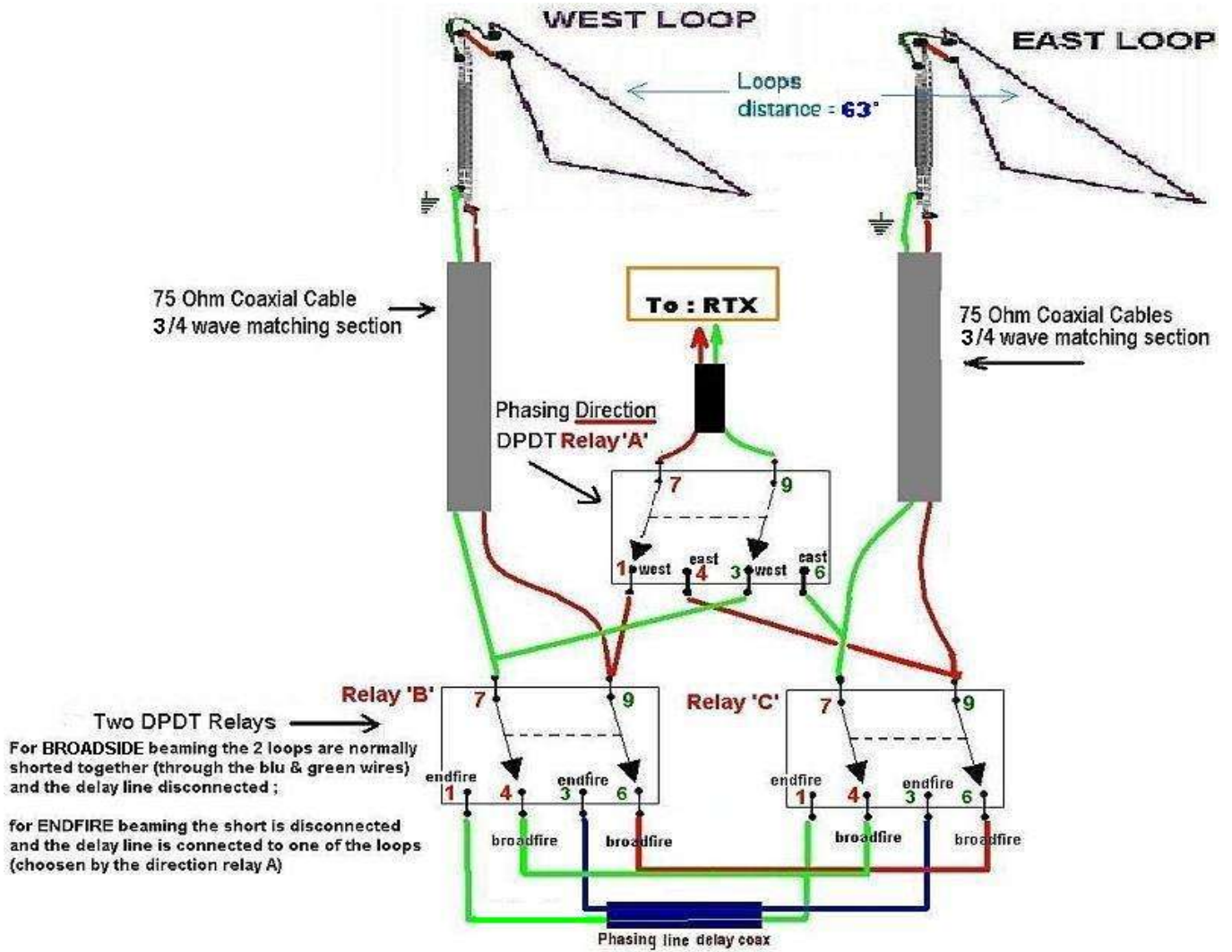

For **BROADSIDE beaming** the 2 loops are normally shorted together (through the blue & green wires) and the delay line is disconnected.

For **ENDFIRE beaming** the short is disconnected and the delay line is connected to one of the loops (chosen by the direction relay A).

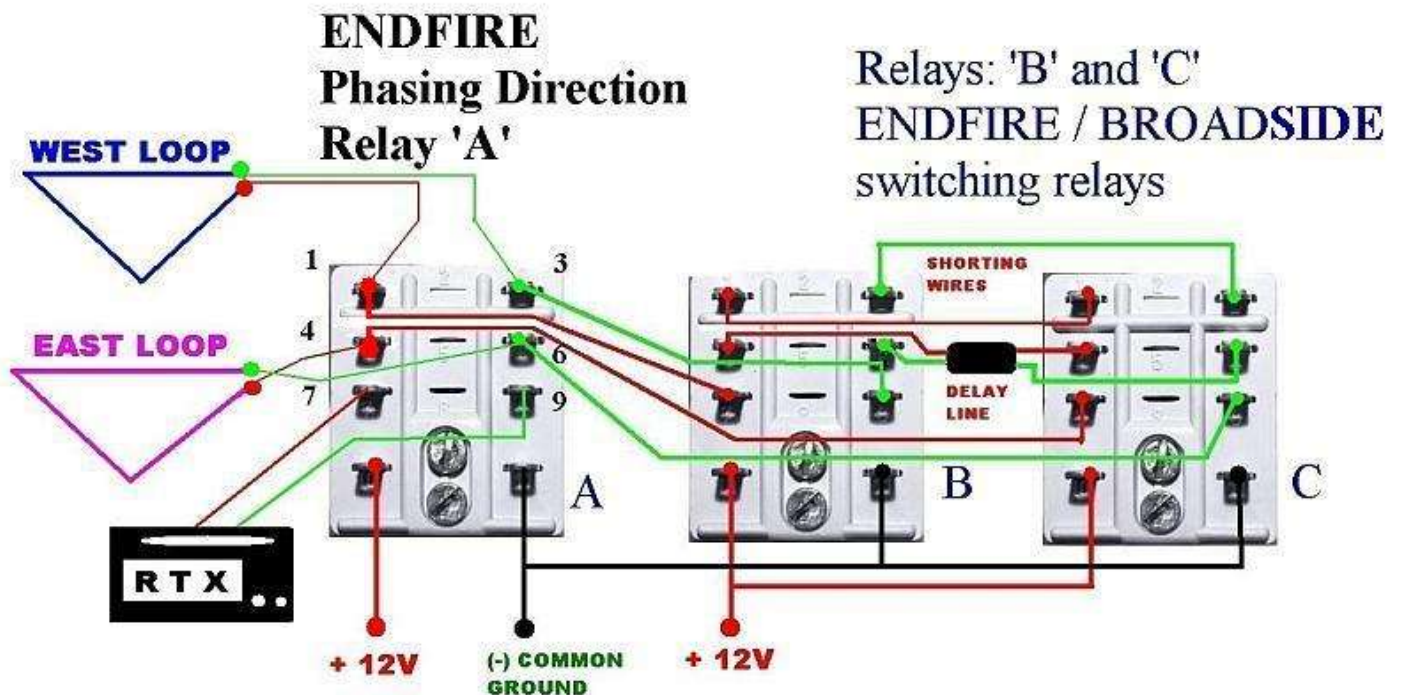

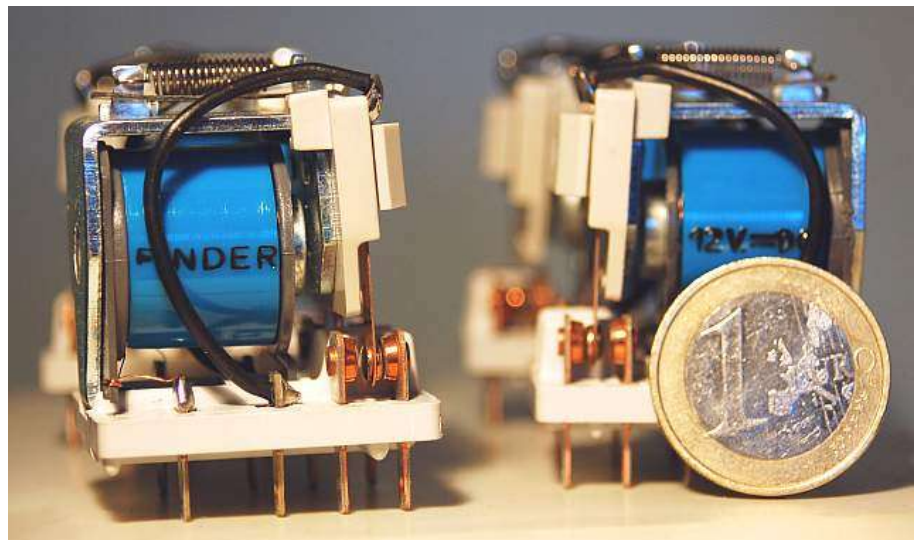

I am provisionally using three cheap **DPDT** (Double Pole, Double Throw) Relays of the brand **Finder 12V – 10A**, Teflon insulation.

I normally use only 400W max on HF) => $P = 500W \Rightarrow P = I^2 \times R \Rightarrow I^2 = 10$ so: $I = 3.16 A$) so 10A max should be ok.

(I believe that their Finder reference number is: 60.62.9.012.0.0.0 I bought four of them for 3,5 Euro each on eBay..! © HI... I will hopefully get better RF relays in a second time.. this is only a provisional experiment!)

In the relay schematic you will notice that the contacts 1-7 and 3-9 are normally shorted and 4-7 and 6-9 are opened without 12V tension; while with the 12 V tension the 1-7 and 3-9 are opened and 4-7 and 6-9 are closed.

I used my system to keep the broadside configuration and also to be able to use Endfire beaming East or West.

Sigi, DG9BFC & Paul N2PL did help me a lot with many 4NEC2 & MMANGAL simulations and suggestions for the phasing section length but I did have to find the best solution by myself empirically using many cuts of RG58U.

My loops distance is about 13.5m = 63°. I firstly used a delay line of 8m to 9m of RG58U coax:
 $f = 3,775 \text{ MHz} \rightarrow \text{wave length} = 79.39 \text{ m} : 360 = 0.22 \text{ m electrical (1 degree)}$.
 14mt. elements distance = **63.7° distance** => so I used 60 degree -> $60^\circ \times 0.22(1\text{m}) \times 0.66 \text{ vl} = \mathbf{8.7\text{m delay line}}$ but this was not working because the F/B was unfortunately negligible . The simulation software 4NEC2 suggested to Paul 131° of phasing section but this length of RG58 (19m) gave 'practically' a very small F/B..

In order to 'simulate' an ENDFIRE beaming to one direction it is useful to get a high F/B with the opposite direction in the order of -15-20dB ! For this reason it was important to find the best length. Some wise OM, like N2PD use a L network to properly phase the array: <http://techdoc.kvindesland.no/radio/ymse1/20061117162439060.pdf> anyway rollers & variable capacitors are expensive for a cheap highlander OM like me and good RF components are not easy to find around here. So I did the phasing in the mountain way :-): trying with many cuts of RG58.. I did many tests with different phasing line lengths in meter: 5-6-7-8-9-10-11-12-13-14-16-17-19-22m of RG58U...

I verified that **the best F/B was with measures from 14m to 16,2m** (where 16.1m looks like the best figure) but I was not able to tell what is "precisely" the best cut because I need a very stable source signal. I got, with many dozens of tests with different measures and signal sources, the best F/B of about 12dB with 14m to 16m (73 to 110 degrees) whether beaming to east stations or west stations. I now use a **delay phasing line of 16.1m** (52,8' = 110 degrees) of RG58 with a F/B that peaks to **15dB** with some stations and that is normally at least 10dB.

Provisional RESULTS: The **elevation angle is about 30°** for 4nec2 (I hope less in reality HI). I pick up easily many Dx stations, it is the best antenna I ever used, better than the Phased Half square Array and the 2 or 3 elements monoband Yagi for the 80m at the same low height (only 14m from the ground).

With BROADSIDE (elements shorted together) the antenna works well, I get many Dx stations from America.

With ENDFIRE I got max 12-15 dB of F/B. In addition, when switching to any direction, the modulations from that direction come out **clearer** than with the simple Broadside mode..

Vertical plane NEC plot with the 110 degrees phasing line:

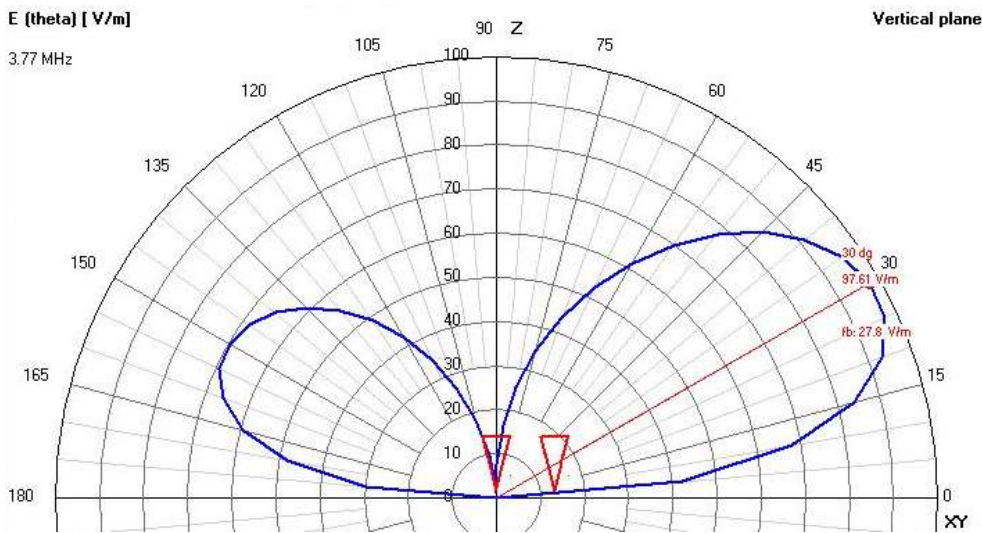

The NEC file can be downloaded here: http://iz5ljb.eu/sgg/IZ5LJB_phased-delta.out and viewed with 4NEC2freeware. **I will be thankful for corrections of the simulation and any advice.**

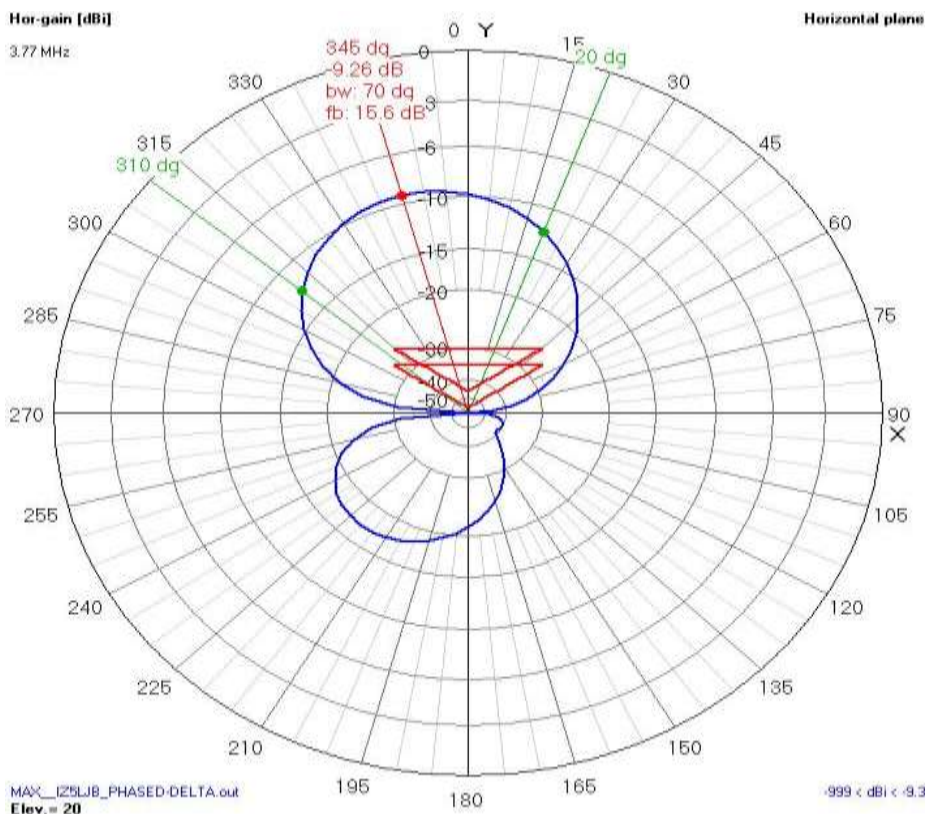

Pictures of the 2 delta loop antennas:

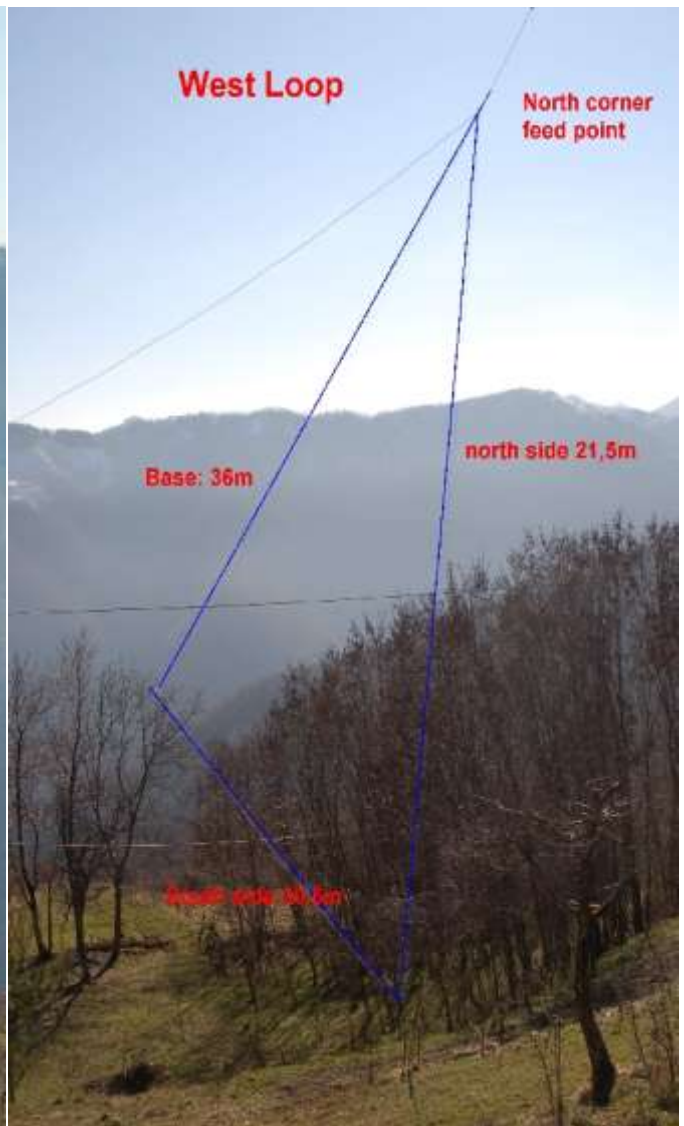
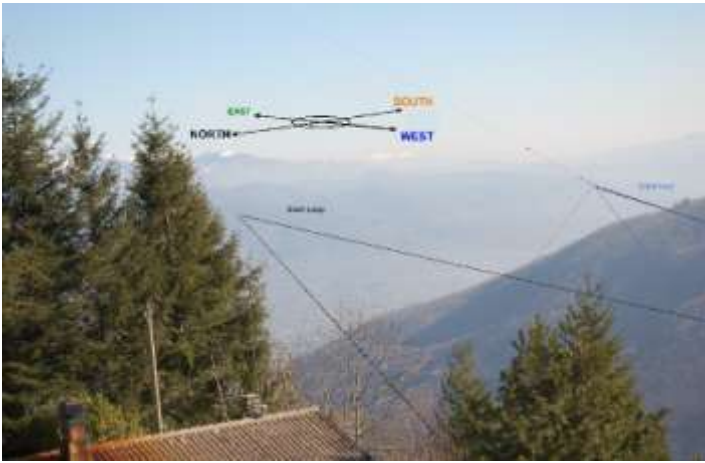

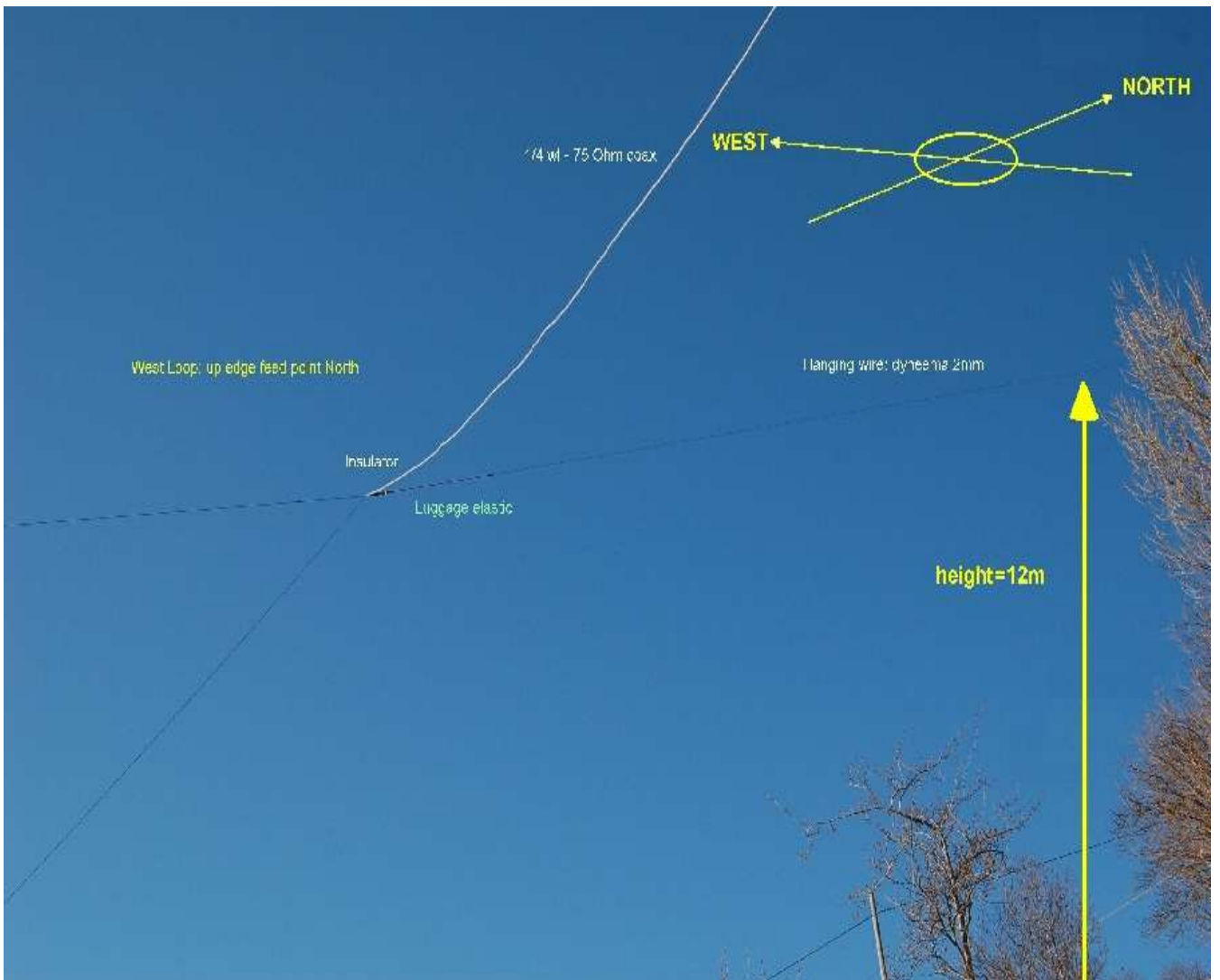
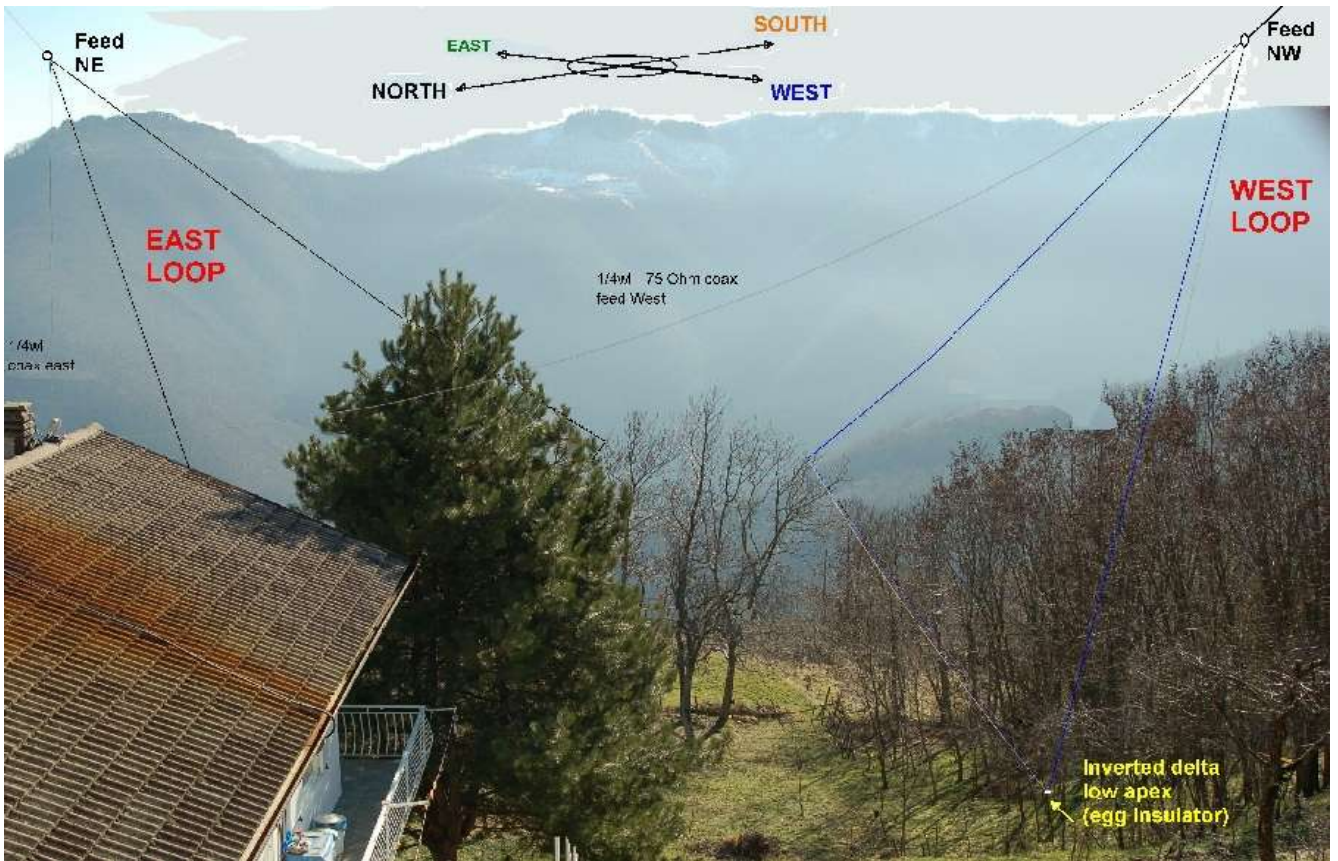

Special thanks to: **I1BAW, DG9BFC, N2PL, WH2T, K4SO, W8JI, PA0SIM** and all the others OM who helped me